



TDS46M

Stainless Steel

Thermodynamic Steam Trap with Maintainable Seat

Description

The TDS46M is a stainless steel, thermodynamic steam trap that has been specifically designed for low capacity applications up to 46 bar g (667 psi g) (where pipe connections permit).

As standard the unit is available with either screwed, socket weld or flanged connections.

- TDS46M benefits:**
- Integral strainer.
 - Integral air vent.
 - Insulation cap.
 - Replaceable seat.

Optional extras

At extra cost a **BDV1** integral blowdown valve can be pre-fitted to the strainer cap, please specify at the time of order placement.

Standards

This product fully complies with the requirements of the European Pressure Equipment Directive 2014/68/EU.

Certification

These products are available with certification to EN 10204 3.1.

Note: All certification/inspection requirements must be specified at the time of order placement.

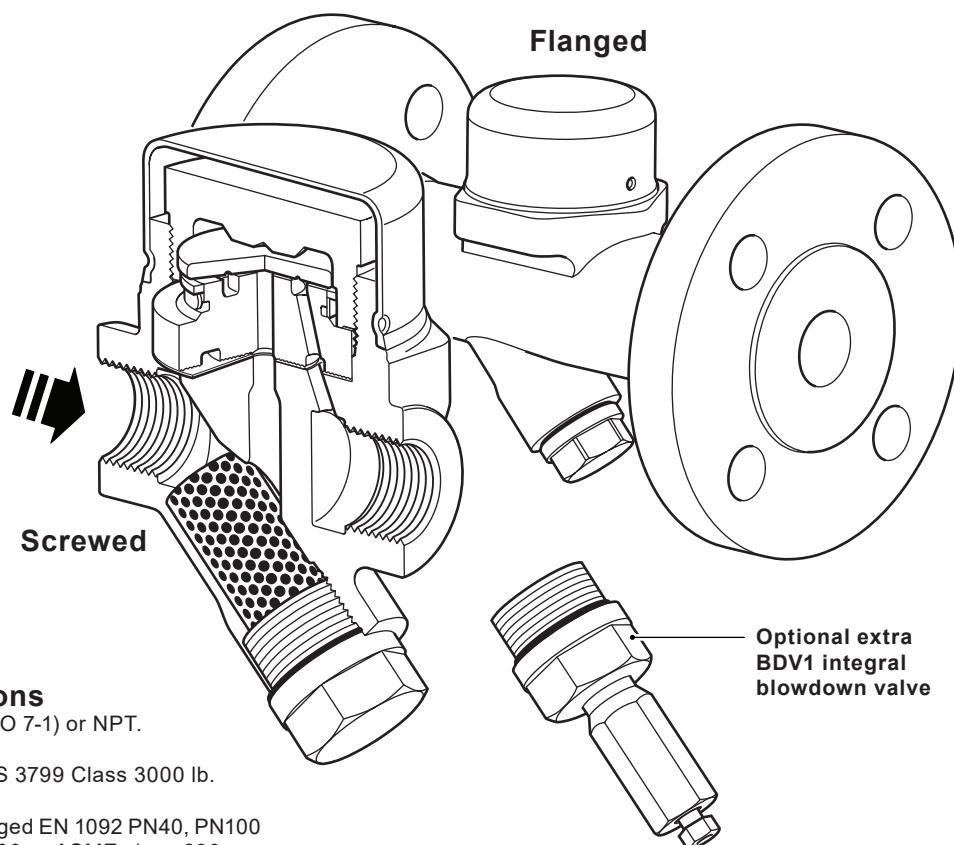

Sizes and pipe connections

½", ¾" and 1" screwed BSP T Rp (ISO 7-1) or NPT.

½", ¾" and 1" socket weld ends to BS 3799 Class 3000 lb.

DN15, DN20 and DN25 integrally flanged EN 1092 PN40, PN100 and ASME class 150, ASME class 300 or ASME class 600.

Materials

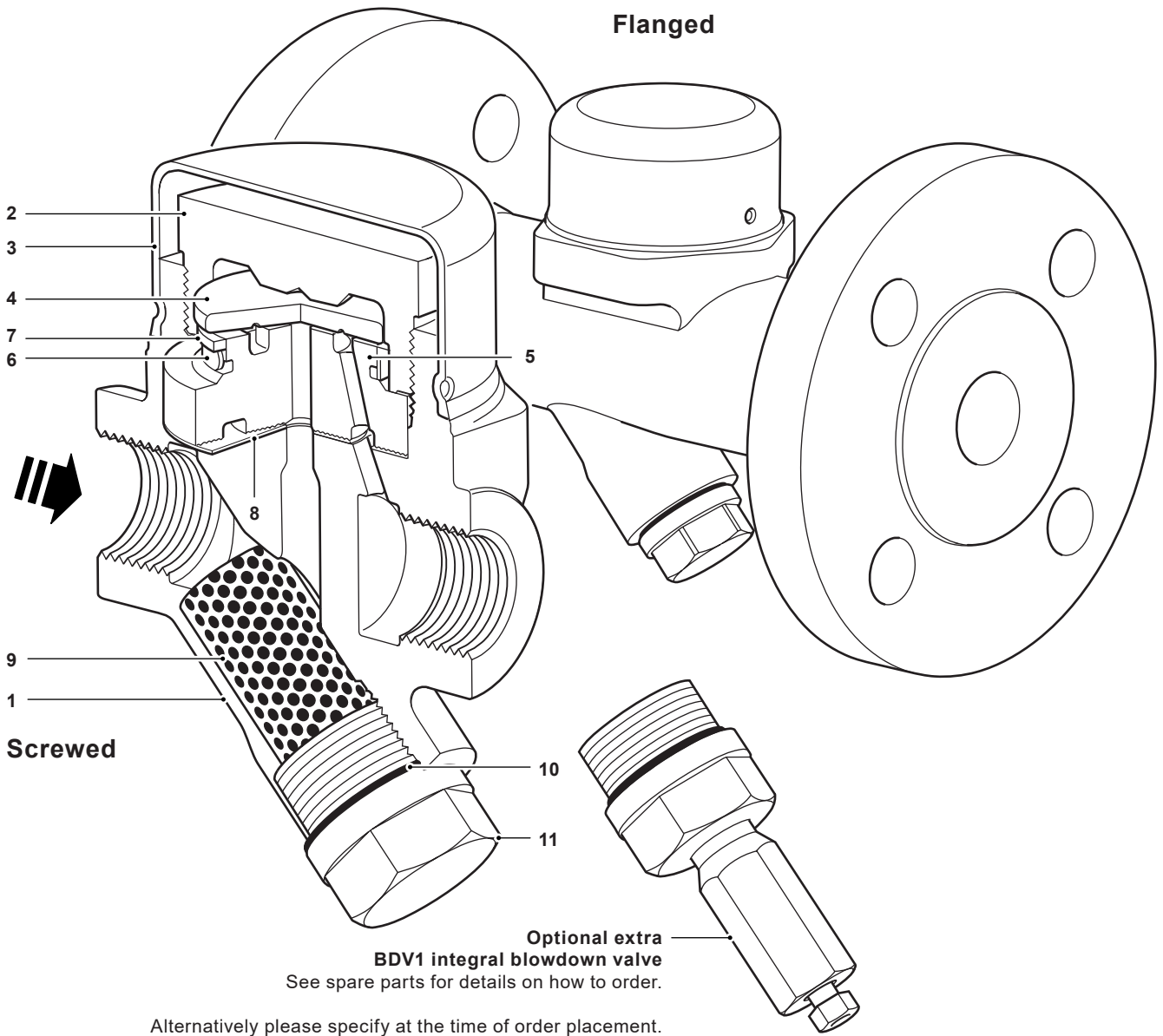

No.	Part	Material	
1	Body	Stainless steel	1.4308/ASTM A351 CF8
2	Top cap	Stainless steel (ENP coated)	1.4301/ASTM A479 304
3	Insulating cover	Stainless steel	EN 10088-1 1.4301
4	Disc	Hardened steel	1.2379
5	Seat	Hardened steel	1.2379
6	Bimetal ring	Bimetal	
7	Support	Stainless steel	AISI 304
8	Seat gasket	Graphite foil	
9	Strainer screen	Stainless steel	ASTM A478 316L
10	Strainer cap gasket	Stainless steel	AISI 304
11	Strainer cap	Stainless steel (ENP coated)	1.4308/ASTM A351 CF8

Pressure/temperature limits (ISO 6552) - Screwed, Socket weld and Flanged EN 1092

Screwed
Socket weld
Flanged:
PN40
PN100

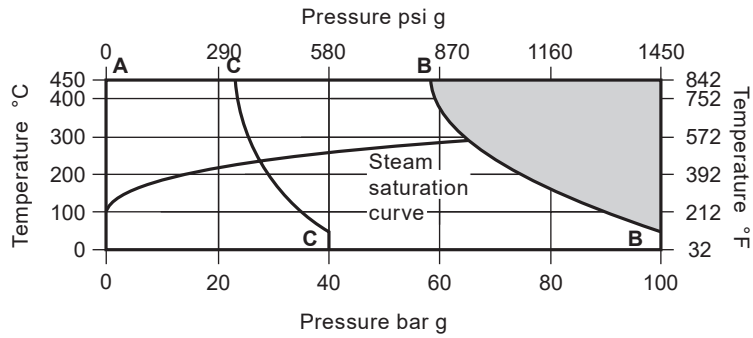

The product **must not** be used in this region or beyond the parameter of the PMA or TMA of the relative end connection.

	Body design conditions		PN100	
	PMA	Maximum allowable pressure	100 bar g @ 50 °C 1450 psi g @ 122 °F	
	TMA	Maximum allowable temperature	450 °C @ 58.3 bar g 842 °F @ 846 psi g	
		Minimum allowable temperature	-50 °C -58 °F	
A - B - B	PN100 Screwed Socket weld	PMO	Maximum operating pressure	46 bar g @ 450 °C 667 psi g @ 842 °F
		TMO	Maximum operating temperature	450 °C @ 46 bar g 842 °F @ 667 psi g
			Minimum operating temperature	0 °C 32 °F
			Minimum operating pressure	1.5 bar g 22 psi g
			Maximum operating backpressure	80% of upstream pressure
			Designed for a maximum cold hydraulic pressure of:	150 bar g 2176 psi g
	Body design conditions		PN40	
	PMA	Maximum allowable pressure	40 bar g @ 50 °C 580 psi g @ 122 °F	
	TMA	Maximum allowable temperature	450 °C @ 23.3 bar g 842 °F @ 338 psi g	
		Minimum allowable temperature	-50 °C -58 °F	
A - C - C	PN40	PMO	Maximum operating pressure for saturated steam service	28.4 bar g @ 233 °C 412 psi g @ 451 °F
		TMO	Maximum operating temperature	450 °C @ 23.3 bar g 842 °F @ 338 psi g
			Minimum operating temperature	0 °C 32 °F
			Minimum operating pressure	1.5 bar g 22 psi g
			Maximum operating backpressure	80% of upstream pressure
			Designed for a maximum cold hydraulic pressure of:	60 bar g 870 psi g

Pressure/temperature limits (ISO 6552) - Flanged ASME

Flanged:
ASME Class 150
ASME Class 300
ASME Class 600

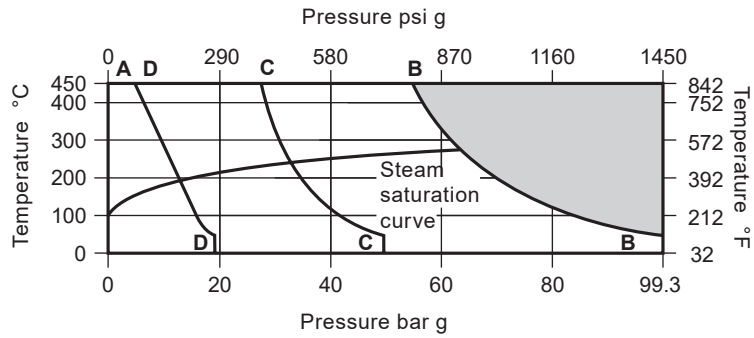

The product **must not** be used in this region or beyond the parameter of the PMA or TMA of the relative end connection.

		Body design conditions	ASME Class 600	
A - B - B	ASME 600	PMA Maximum allowable pressure	99.3 bar g @ 38 °C	1440 psi g @ 100 °F
		TMA Maximum allowable temperature	450 °C @ 54.8 bar g	842 °F @ 795 psi g
		Minimum allowable temperature	-50 °C	-58 °F
		PMO Maximum operating pressure	46 bar g	667 psi g
		TMO Maximum operating temperature	450 °C @ 46 bar g	842 °F @ 667 psi g
		Minimum operating temperature	0 °C	32 °F
		Minimum operating pressure	1.5 bar g	22 psi g
		Maximum operating backpressure	80% of the upstream pressure	
		Designed for a maximum cold hydraulic pressure of:	149 bar g	2161 psi g
				Body design conditions
A - C - C	ASME 300	PMA Maximum allowable pressure	49.6 bar g @ 38 °C	719 psi g @ 100 °F
		TMA Maximum allowable temperature	450 °C @ 27.4 bar g	842 °F @ 397 psi g
		Minimum allowable temperature	-50 °C	-58 °F
		PMO Maximum operating pressure for saturated steam service	33 bar g	479 psi g
		TMO Maximum operating temperature	450 °C @ 27.4 bar g	842 °F @ 397 psi g
		Minimum operating temperature	0 °C	32 °F
		Minimum operating pressure	1.5 bar g	22 psi g
		Maximum operating backpressure	80% of the upstream pressure	
Designed for a maximum cold hydraulic pressure of:	74.4 bar g	1079 psi g		
		Body design conditions	ASME Class 150	
A - D - D	ASME 150	PMA Maximum allowable pressure	19 bar g @ 38 °C	276 psi g @ 100 °F
		TMA Maximum allowable temperature	450 °C @ 4.6 bar g	842 °F @ 67 psi g
		Minimum allowable temperature	-50 °C	-58 °F
		PMO Maximum operating pressure for saturated steam service	14 bar g	203 psi g
		TMO Maximum operating temperature	450 °C @ 4.6 bar g	842 °F @ 67 psi g
		Minimum operating temperature	0 °C	32 °F
		Minimum operating pressure	1.5 bar g	22 psi g
Maximum operating backpressure	80% of the upstream pressure			
Designed for a maximum cold hydraulic pressure of:	28.5 bar g	22 psi g		

Dimensions (approximate) in mm (in)

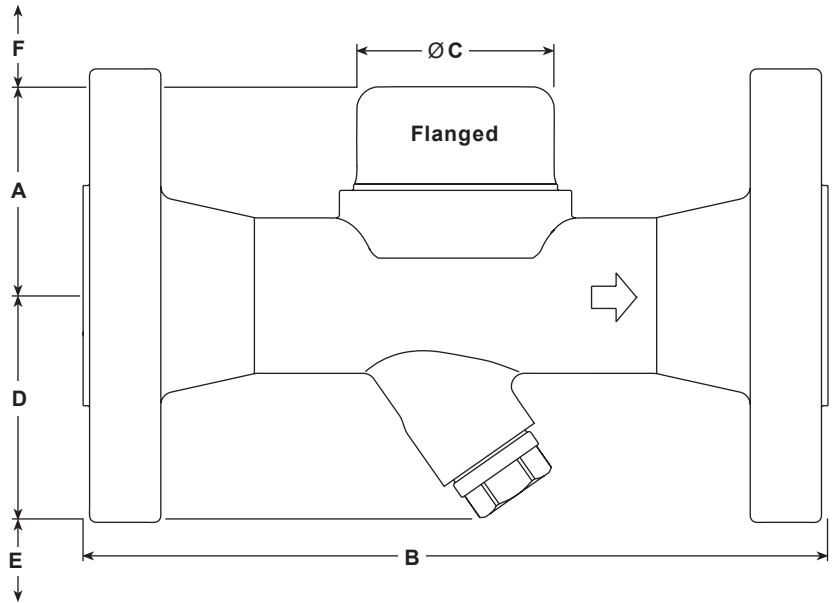
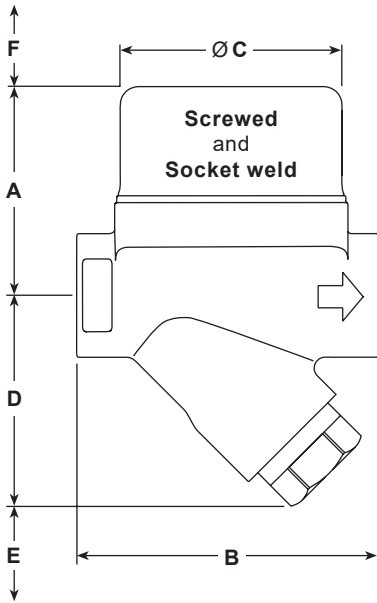

Size	A	B		C	D	E	F		
		Screwed	Socket weld					Flanged	Withdrawal distance
				PN40 ASME 150, 300, 600	PN100				
1/2" DN15	58 (2.28)	78 (3.07)	92 (3.62)	150 (5.91)	210 (8.27)	61 (2.40)	59 (2.32)	40 (1.57)	30 (1.18)
3/4" DN20	61 (2.40)	95 (3.74)							
1" DN25	65 (2.56)				230 (9.06)				

Weights (approximate) in kg (lbs)

Size	Screwed	Socket weld	Flanged				
			ASME 150	ASME 300	ASME 600	PN40	PN100
1/2" DN15	1.38 (3.04)	1.49 (3.28)	2.46 (5.42)	2.96 (6.53)	3.06 (6.75)	3.06 (6.75)	4.36 (9.61)
3/4" DN20	1.64 (3.62)	1.64 (3.62)	3.16 (6.97)	4.06 (8.95)	4.26 (9.39)	3.96 (8.73)	6.26 (13.8)
1" DN25	1.90 (4.19)	1.90 (4.19)	4.16 (9.17)	5.16 (11.4)	5.46 (12.0)	4.86 (10.7)	8.16 (18.0)

Capacities

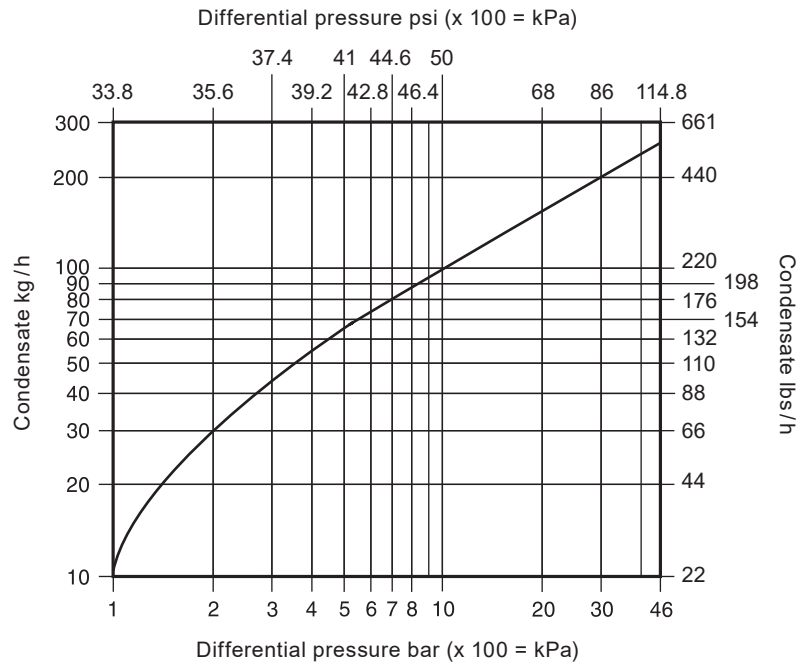

Safety information, installation and maintenance

For full details see the Installation and Maintenance Instructions (IM-P187-05) supplied with the product.

Installation note:

The TDS46M is designed for installation with the disc in a horizontal plane with the insulating cover at the top.

It is recommended that a non-return valve is fitted when discharging condensate into return lines where backpressure is experienced. It is also recommended that a diffuser is fitted when discharging to atmosphere.

For ease and maintenance, consideration should be given to fitting isolation valves upstream and downstream of the steam trap.

How to order

Example: 1 off Spirax Sarco DN15 TDS46M thermodynamic steam trap having flanged EN 1092 PN40 connections.

Spare parts

Please note that the spares shown are the same for the screwed, socket weld and flanged versions.

The spare parts available are shown in solid outline. Parts drawn in a grey line are not supplied as spares.

Available spares

Insulating cover	3
Top cap, seat and disc assembly	2, 4, 5, 6, 7, 8
Strainer screen and gasket	9, 10
Set of gaskets (packet of 3 sets)	8, 10
BDV1 blowdown valve retrofit kit	

How to order spares

Always order spares by using the description given in the column headed 'Available spares' and state the size and type of trap.

Example: 1 off Top cap, seat and disc assembly for a Spirax Sarco DN15 TDS46M thermodynamic steam trap.

Cautionary note regarding disassembly and assembly of the unit:

Removal of the following parts:

- top cap (2),
- strainer cap (11) and the
- optional BDV2 retrofit kit should be carried out in a workshop, not whilst the trap is connected to the pipeline (PC) connector.

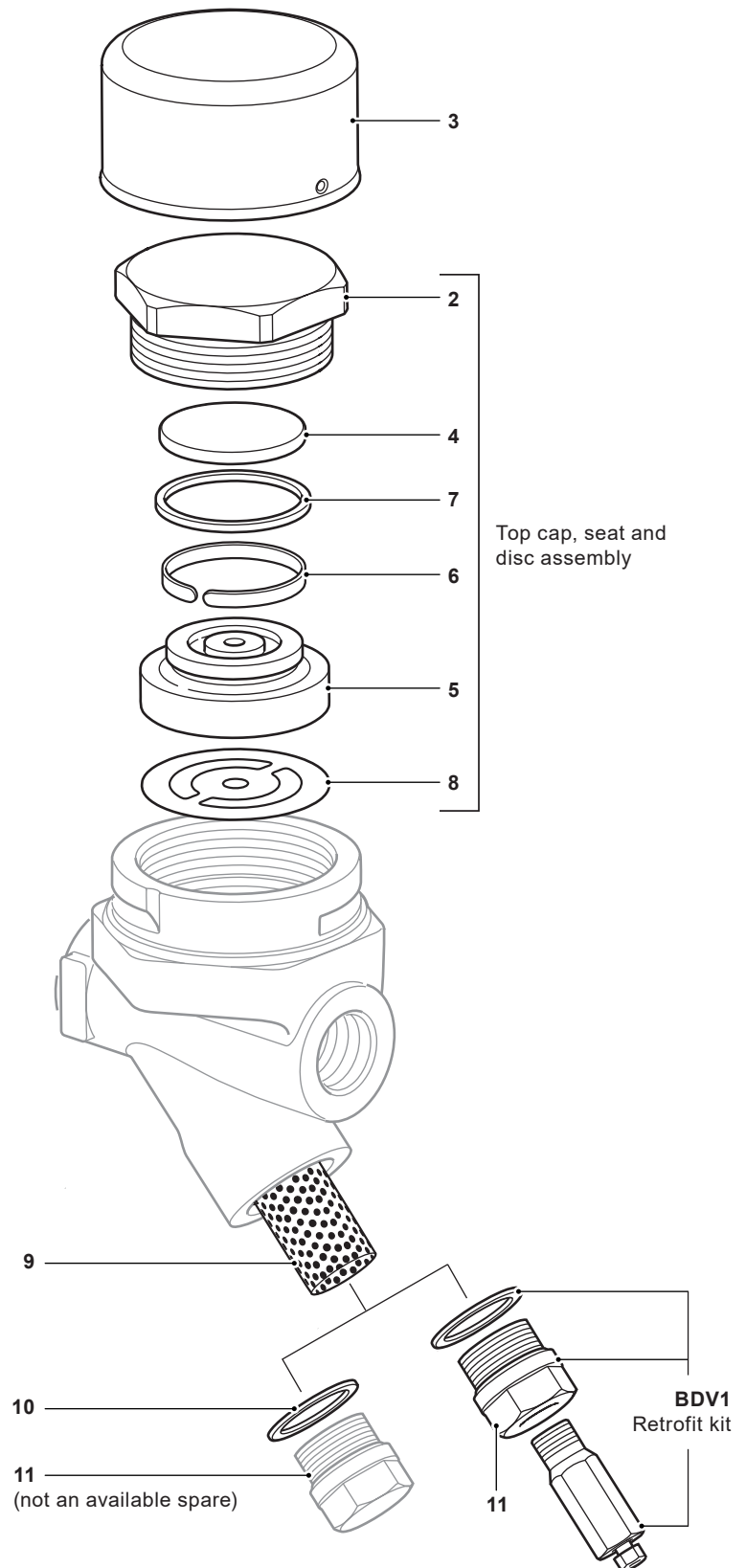

Recommended tightening torques (for suitably lubricated threads)

Item	Part	 mm	N m	(lbf ft)
2	Top cap	50 A/F	400	295
11	Strainer cap	24 A/F	110	46.5 - 48.7