

Solenoid directional valves P_{max} 420 bar

direct operated, ISO 4401 size 10

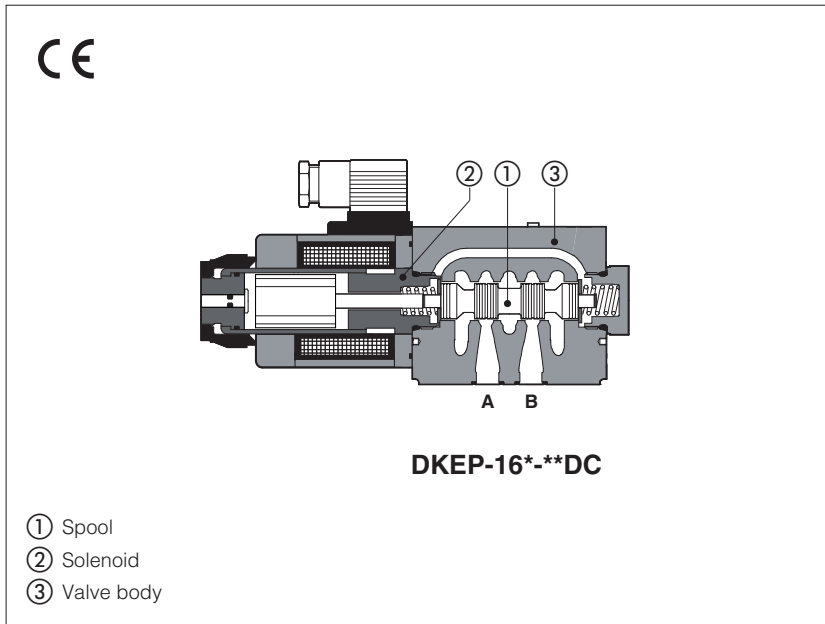

DKEP

Spool type, direct operated solenoid valves with max pressure up to 420 bar for heavy duty applications.

They are equipped with threaded solenoids certified according the North American standard **CURUS**

Single and double solenoid valves are available in two or three position configurations and with a wide range of interchangeable spools ①, see section ②.

Solenoids ② are made by:

- wet type screwed tube, different for AC and DC power supply, with integrated manual override pin.
- interchangeable coils, specific for AC or DC power supply, easily replaceable without tools - see section ⑥ for available voltages

Standard coils protection IP65 (once correctly assembled with relevant electric connectors).

The valve body ③ is made by high strength cast iron.

Mounting surface ISO 4401 size **10**

Max flow up to **150** l/min

Max pressure: **420** bar

1 MODEL CODE

DKEP - 1	61	0	/A	X	24 DC	**	/*
Directional control valves DKEP-1 = Size 10							Seals material, see sect. ③, ④: - = NBR PE = FKM BT = NBR low temperature
Valve configuration, see table ② 61 = single solenoid, center plus external position, spring centered 63 = single solenoid, 2 external positions, spring offset 67 = single solenoid, center plus external position, spring offset 71 = double solenoid, 3 positions, spring centered 75 = double solenoid, 2 external positions, with detent							Series number
Spool type, see section ②							Voltage code, see section ⑥
Options, see note 1 at section ⑦							
				00-AC = AC solenoids without coils 00-DC = DC solenoids without coils X = without connector See section ⑩ for available connectors, to be ordered separately Coils with special connectors, see section ⑭ XJ = AMP Junior Timer connector XK = Deutsch connector XS = Lead Wire connection			

2 CONFIGURATIONS and SPOOLS

Configurations	Spools	Configurations	Spools
<p>61</p> <p>61/A</p> <p>67</p> <p>67/A</p> <p>71</p>	<p>1 0 2</p> <p>1 0 2</p> <p>1 0 2</p> <p>1 0 2</p> <p>5</p> <p>6</p> <p>7</p> <p>8</p> <p>91</p> <p>19</p> <p>93</p> <p>39</p> <p>1/9</p> <p>58</p> <p>only for configuration 71</p>	<p>63</p> <p>63/A</p> <p>75</p>	<p>1 0 2</p> <p>0/2</p> <p>1/2</p> <p>2/2</p>

3 GENERAL CHARACTERISTICS

Assembly position	Any position
Subplate surface finishing to ISO 4401	Acceptable roughness index, Ra 0,8 recommended Ra 0,4 - flatness ratio 0,01/100
MTTFd valves according to EN ISO 13849	150 years, see technical table P007
Ambient temperature range	Standard = -30°C ÷ +70°C /PE option = -20°C ÷ +70°C /BT option = -40°C ÷ +60°C
Storage temperature range	Standard = -30°C ÷ +80°C /PE option = -20°C ÷ +80°C /BT option = -40°C ÷ +80°C
Surface protection	Body: zinc coating with black passivation Coil: zinc nickel coating (DC version) plastic incapsulation (AC version)
Corrosion resistance	Salt spray test (EN ISO 9227) > 200 h
Compliance	CE to Low Voltage Directive 2014/35/EU RoHS Directive 2011/65/EU as last update by 2015/863/EU REACH Regulation (EC) n°1907/2006

4 HYDRAULIC CHARACTERISTICS

Operating pressure	Ports P,A,B: 420 bar; Port T 210 bar for DC version; (350 bar for option /Y); 160 bar for AC version
Max flow	150 l/min , see Q/Δp diagram at section 9 and operating limits at section 10

5 ELECTRICAL CHARACTERISTICS

Insulation class	H (180°C) for DC coils; F (155°C) for AC coils Due to the occurring surface temperatures of the solenoid coils, the European standards EN ISO 13732-1 and EN ISO 4413 must be taken into account
Protection degree to DIN EN 60529	IP 65 (with connectors 666, 667, 669 or E-SD correctly assembled)
Relative duty factor	100%
Supply voltage and frequency	See section 6
Supply voltage tolerance	± 10%

6 COIL VOLTAGE

External supply nominal voltage ± 10%	Voltage code	Type of connector	Power consumption (2)	Code of spare coil	
12 DC	12 DC	666 or 667	36 W	CAE-12DC	
14 DC	14 DC			CAE-14DC	
24 DC	24 DC			CAE-24DC	
28 DC	28 DC			CAE-28DC	
110 DC	110 DC			CAE-110DC	
125 DC	125 DC			CAE-125DC	
220 DC	220 DC			CAE-220DC	
110/50/60 AC	110/50/60 AC			100 VA (3)	CAE-110/50/60AC (1)
230/50/60 AC	230/50/60 AC				CAE-230/50/60AC (1)
115/50 AC	115/60 AC			130 VA (3)	CAE-115/60AC
230/50 AC	230/60 AC	CAE-230/60AC			
110/50/60 AC	110 DC	669	36 W	CAE-110DC	
230/50/60 AC	220 DC			CAE-220DC	

- (1) Coil can be supplied also with 60 Hz of voltage frequency; in this case the performances are reduced by 10 ÷ 15% and the power consumption is 90 VA.
(2) Average values based on tests performed at nominal hydraulic condition and ambient/coil temperature of 20°C.
(3) When solenoid is energized, the inrush current is approx 3 times the holding current.

7 NOTES FOR DKEP

1 Options

- A** = Solenoid mounted at side of port B (only for single solenoid valves). In standard versions, solenoid is mounted at side of port A.
- WP** = prolonged manual override protected by rubber cap.
- L7, L8** see section 8 = device for switching time control (only for DC solenoids), available only for spool type 0/1, 1/1, 3/1, 4 and 5.
- Y** = external drain, only for DC version, to be selected if the pressure at T port is higher than the max allowed limits.



The manual override operation can be possible only if the pressure at T port is lower than 50 bar

WPD/KE-DC = manual override with detent, to be ordered separately, see tab. K150

2 Special spools

- spools type **0** and **3** are also available as **0/1** and **3/1** with restricted oil passages in central position, from user ports to tank.
- spools type **1** is also available as **1/1**, properly shaped to reduce the water-hammer shocks during the switching.
- spool type **1/9** has closed center in rest position but it avoids the pressurization of A and B ports due to the internal leakages.
- other types of spools can be supplied on request.

8 DEVICES FOR SWITCHING TIME CONTROL

These devices are only available for DC valve version (5 chambers body) and can control the switching time and therefore reduce the coil hammering in the hydraulic circuit.

- **L7/L8**: controls the switching time in both moving directions of the spool by means of fixed calibrated restrictor (gauged flow). The restrictor is installed in the solenoid's anchor.

For a correct operation of the switching time control, the passage in which the control device is installed must be completely filled with oil.

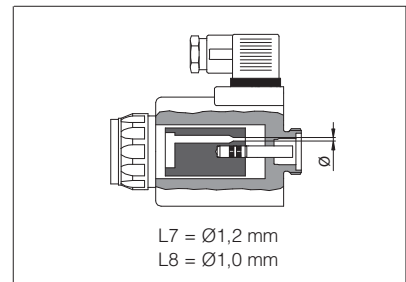

9 Q/P DIAGRAMS based on mineral oil ISO VG 46 at 50°C

Flow direction	P→A	P→B	A→T	B→T	P→T	B→A
Spool type						
0, 0/1, 0/2, 2/2	A	A	B	B		
1, 1/1, 1/3, 6, 8	A	A	D	C		
3, 3/1, 7	A	A	C	D		
4	B	B	B	B	F	
5	A	B	C	C	G	
1/2	B	C	C	B		
2/7	D			F		
5/7	B			A	E	
19	A	D	C			H

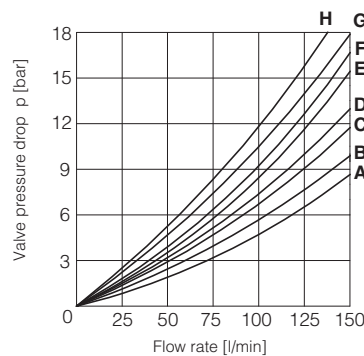

10 OPERATING LIMITS based on mineral oil ISO VG 46 at 50°C

The diagrams have been obtained with warm solenoids and power supply at lowest value ($V_{nom} - 10\%$). The curves refer to application with symmetrical flow through the valve (i.e. P→A and B→T). In case of asymmetric flow and if the valves have the devices for controlling the switching times the operating limits must be reduced.

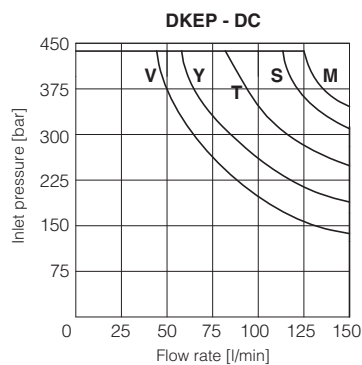
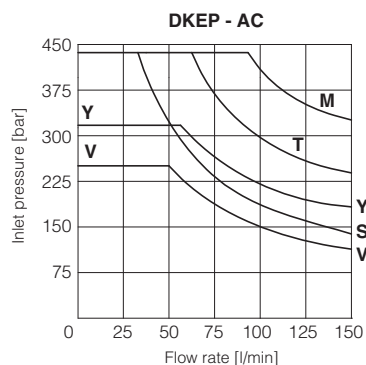

Curve	Spool type	
	AC	DC
M	0/1, 5/7, 1/3	0, 0/1, 1, 1/1, 3, 3/1, 1/2, 0/2, 8
S	2/7, 4, 5, 19	1/3, 5/7, 6, 7
Y	1, 1/2, 0/2	4, 5, 2/7
V	6, 7, 8, 2/2	2/2
T	0, 1/1, 3, 3/1	19
U	-	4, 5
Z	-	0/1, 1/1, 3/1

11 SWITCHING TIMES (average values in msec)

Valve	Switch-on AC	Switch-on DC	Switch-off AC	Switch-off DC
DKEP + 666 / 667	40	60	25	35

Test conditions:

- 50 l/min; 150 bar
- nominal supply voltage
- 2 bar of back pressure on port T
- mineral oil ISO VG 46 at 50°C

The elasticity of the hydraulic circuit and the variations of the hydraulic characteristics and temperature affect the response time.

12 SWITCHING FREQUENCY

Valve	AC (cycles/h)	DC (cycles/h)
DKEP + 666 / 667	7200	15000

13 ELECTRIC CONNECTORS ACCORDING TO DIN 43650 (to be ordered separately, see tech table K800)

666 = standard connector IP-65, suitable for direct connection to electric supply source

667 = as 666, but with built-in signal led. Available for power supply voltage 24 AC or DC, 110 AC or DC, 220 AC or DC

669 = with built-in rectifier bridge for supplying DC coils by alternate current (AC 110V and 230V - I_{max} 1A)

14 COIL WITH SPECIAL CONNECTORS only for voltage supply **12, 14, 24, 28 Vdc**

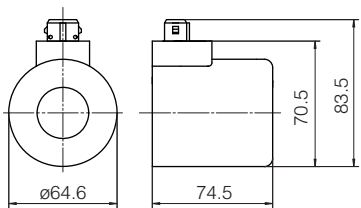
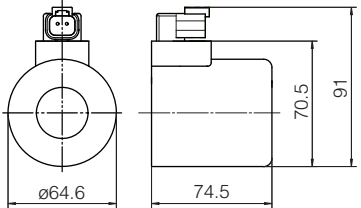
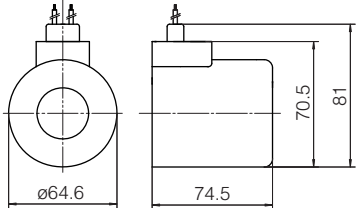
AMP Junior timer connector	Deutsch connector DT-04-2P	Lead Wire connection
 <p>Options -XJ Coil type CAEJ AMP Junior Timer connector Protection degree IP67</p>	 <p>Options -XK Coil type CAEK Deutsch connector DT-04-2P male Protection degree IP67</p>	 <p>Options -XS Coil type CAES Lead Wire connection Cable lenght = 180 mm</p>

Note: for the electric characteristics refer to standard coils features - see section 16

15 SEALS AND HYDRAULIC FLUIDS - for other fluids not included in below table, consult our technical office

Seals, recommended fluid temperature	NBR seals (standard) = -20°C ÷ +80°C, with HFC hydraulic fluids = -20°C ÷ +50°C FKM seals (/PE option) = -20°C ÷ +80°C NBR low temp. seals (/BT option) = -40°C ÷ +60°C, with HFC hydraulic fluids = -40°C ÷ +50°C		
Recommended viscosity	20 ÷ 100 mm ² /s - max allowed range 15 ÷ 380 mm ² /s		
Max fluid contamination level	normal operation	ISO4406 class 18/16/13 NAS1638 class 7	see also filter section at www.atos.com or KTF catalog
	longer life	ISO4406 class 16/14/11 NAS1638 class 5	
Hydraulic fluid	Suitable seals type	Classification	Ref. Standard
Mineral oils	NBR, FKM, NBR low temp.	HL, HLP, HLPD, HVLP, HVLPD	DIN 51524
Flame resistant without water	FKM	HFDR, HFDR	ISO 12922
Flame resistant with water	NBR, NBR low temp.	HFC	

16 FASTENING BOLTS AND SEALS

Fastening bolts	Seals
4 socket head screws M6x40 class 12.9 Tightening torque = 15 Nm	5 OR 2050; (1 OR 108 for Y optional port); Diameter of ports A, B, P, T: Ø 11.5mm (max); Y: Ø 5mm (optional port)

17 INSTALLATION DIMENSIONS [mm]

ISO 4401: 2005
 Mounting surface according to 4401-05-05-0-05
 (without X port, Y port optional)

Mass (Kg)		
	DC	AC
DKEP-16	4,5	3,9
DKEP-17	6,1	4,7

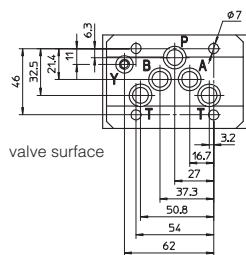

P = PRESSURE PORT
 A, B = USE PORT
 T = TANK PORT
 Y = DRAIN PORT (optional)

DKEP-16*-DC

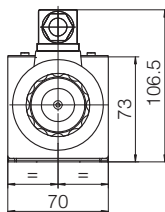
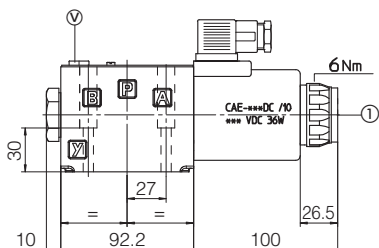

DKEP-16*/A-DC

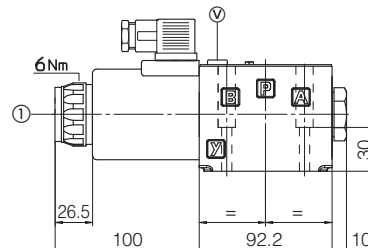

DKEP-17*-DC

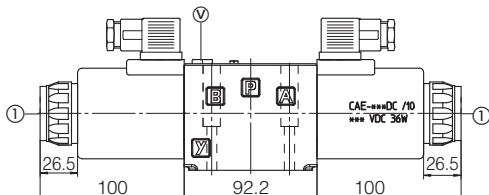

DKEP-16*-AC

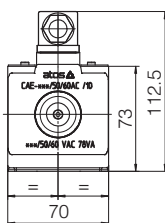
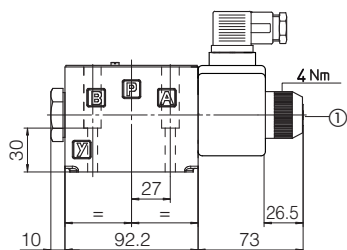

DKEP-16*-AC

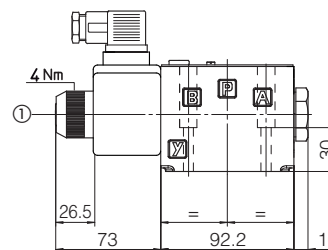

DKEP-17*-AC

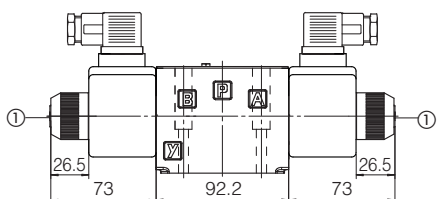

Overall dimensions refer to valves with connectors type 666

- ① Standard manual override PIN. The manual override operation can be possible only if the pressure at T ports is lower than 50 bar
- Ⓞ Option L, L1, L2, L3, LR

18 MANUAL OVERRIDE

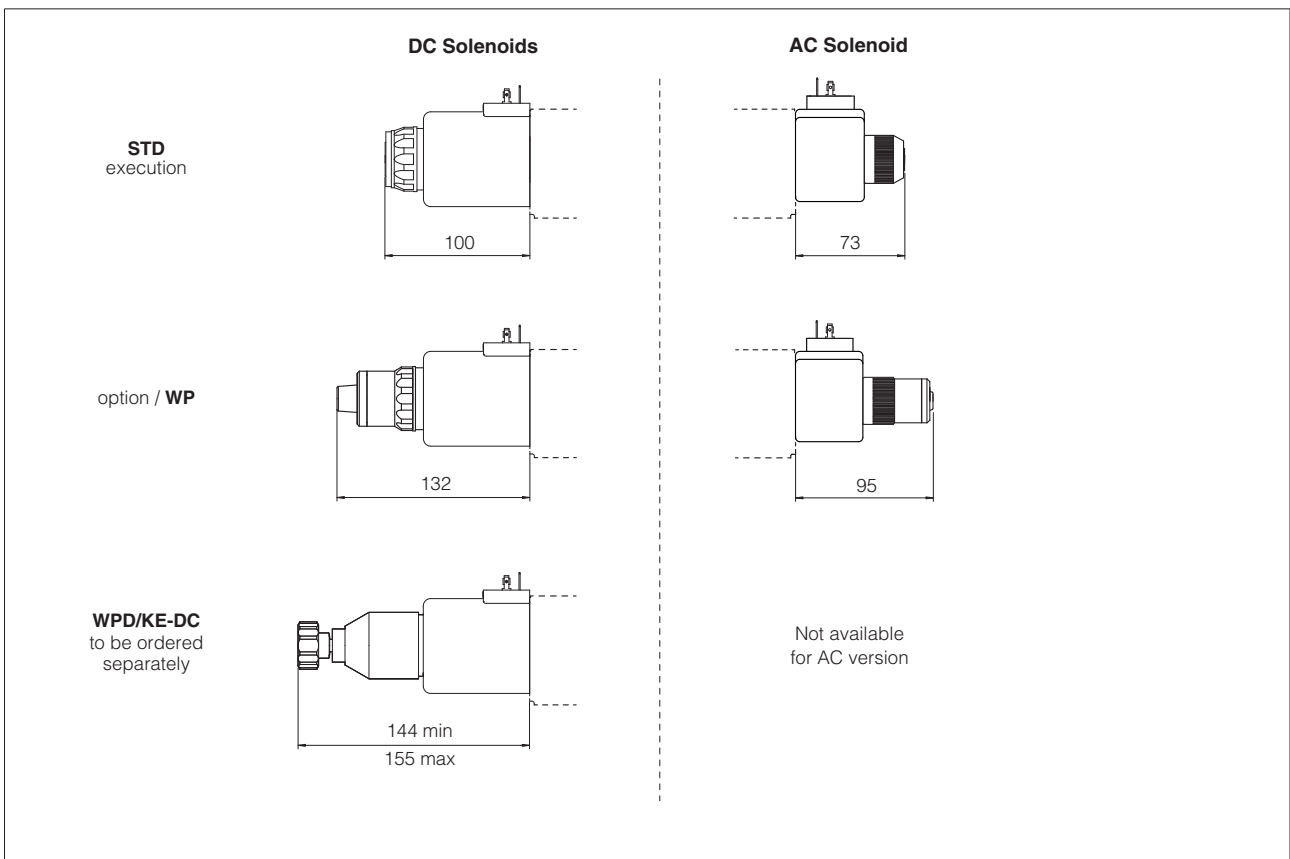

19 RELATED DOCUMENTATION

E001	Basics for solenoid directional valves	P005	Mounting surfaces for electrohydraulic valves
K150	Handweels for hydraulic controls	E900	Operating and maintenance information
K280	Single and modular subplates		
K800	Electric and electronic connectors		