

INT69 V[®], INT69 VS[®], INT69 TM[®]

for heavy start or high switching frequency



INT69 V, INT69 VS



INT69 TM

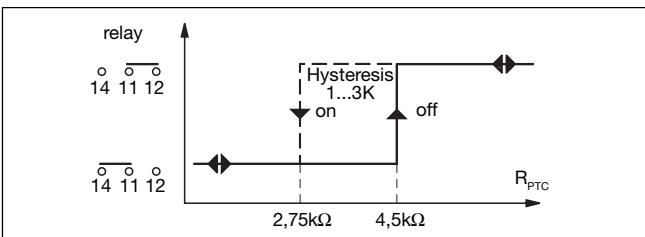

INT69 V

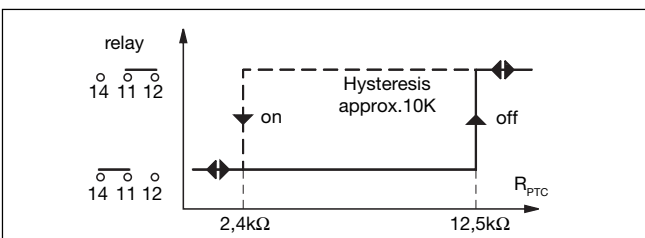

INT69 VS

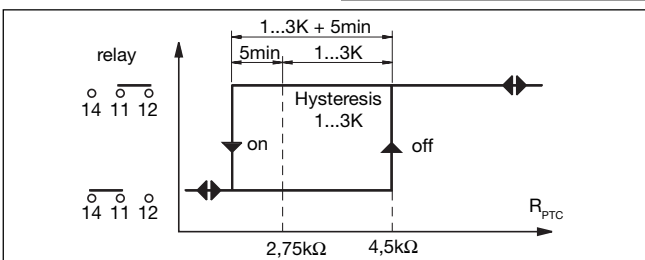

INT69 TM

Application:

The INT69 VS, INT69 V and INT69 TM motor protection modules have been especially

developed for motors with high starting load or drives with high switching frequency.

INT69 V Motor Protection Module:

The INT69 V switching points and hysteresis are similar to those of the INT69 motor protection module. In addition it is equipped with an electronic lock-out function. By inserting a jumper between terminal B1 and B2, lock-out after thermal

shut-down is activated. After the motor windings cool down, the lock-out function can be reset by interrupting the supply voltage, removing the jumper B1-B2 or by depressing the reset button (option).

INT69 VS Motor Protection Module:

Standard PTC control modules are reset after terminal trip when the motor windings have cooled down by approx. 1...3K. For some applications, however, e.g. for motors with high switching frequency (cranes, lifts, winches, etc.) this temperature difference may be too small. The INT69 VS motor protection module has been developed for these special drive applications. Firstly the

switching hysteresis spread, so that a reset temperature difference of approx. 10K is achieved and secondly lock-out can be selected by inserting a jumper (B1-B2). After cooling down, the motor can be restarted if the lock-out function is reset by interrupting the supply voltage, removing the jumper B1-B2 or by depressing the reset button (option).

Note :

Due to the displacement of the trip-point to approx. 12.5kΩ the trip temperature is approx. 10K above the nominal response temperature of the PTC. When the INT69 VS is used, the NAT (nominal response tem-

perature) of the PTC sensors must, therefore be 10K below the required trip temperature.

Example:

NAT=150°C (insulation class F)
NAT=150°C minus 10K=140°C

INT69 TM Motor Protection Module:

The INT69 TM motor protection module has also been designed for motors with high starting load and/or high switching frequency. The extended cool-down period of the INT69 VS protection module is achieved increasing the switching hysteresis, whereas the INT69 TM is equipped with an additional time function for extended cool-

down period. As with the standard control modules, the trip point is 4.5kΩ and thus corresponds to the nominal response temperature of the PTC thermistors. As soon as the PTC resistance drops to 2.5kΩ, the internal timer of the INT69 TM is activated and after approx. 5min the output relay pulls in again.

INT69 V[®], INT69 VS[®], INT69 TM[®]

for heavy start or high switching frequency

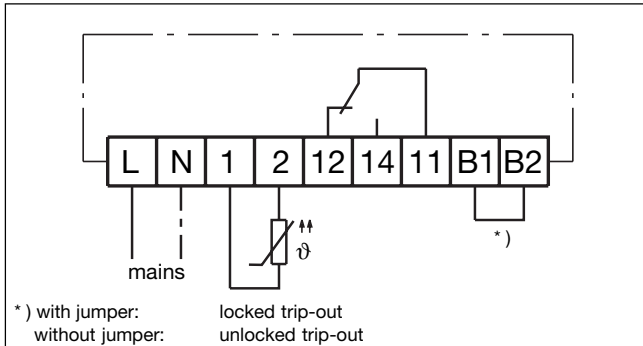

Connection Diagram
INT69 VS, INT69 V

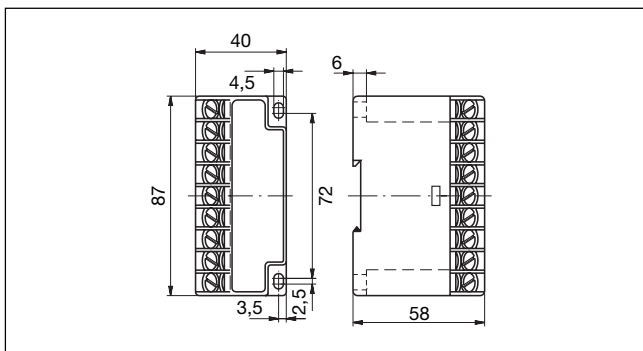

Dimensions in mm
INT69 VS, INT69 V

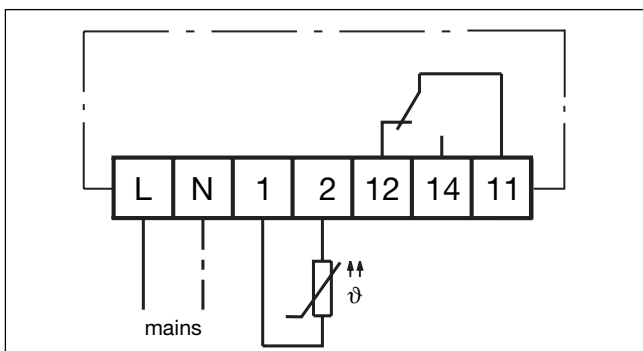

Connection Diagram
INT69 TM

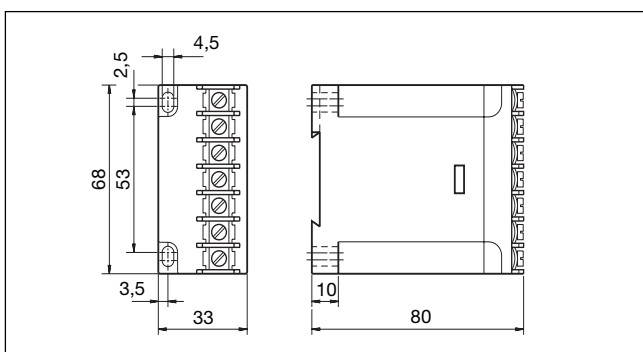

Dimensions in mm
INT69 TM

Technical data general

Supply voltage	AC 50Hz 230V ±10% 3VA
Ambient temperature range	-20...+60°C
Relay	AC 250V, max. 5A, 300VA ind.
Mechanical service life	approx. 1 mio. switching cycles
Protection class acc. to EN 60529	with terminal cover: IP20 without terminal cover: IP00
Housing	PA6 GF30
Mounting	on 35mm standard rail acc. to EN 50022 or base mounted

Technical data INT69 V

Measuring circuit	
- type	PTC, acc. to DIN 44081/082
- number of sensors	1...9 in series
- $R_{25\text{ total}}$	< 1,8k Ω
Switching hysteresis	1...3K
Weight	approx. 200g

Technical data INT69 VS

Measuring circuit	
- type	PTC, acc. to DIN 44081/082
- number of sensors	1...9 in series
- $R_{25\text{ total}}$	< 1,8k Ω
Switching hysteresis	approx. 10K
Weight	approx. 200g

Technical data INT69 TM

Measuring circuit	
- type	PTC, acc. to DIN 44081/082
- number of sensors	1...9 in series
- $R_{25\text{ total}}$	< 1,8k Ω
Switching hysteresis	1...3K, with additional time factor of 5min ± 15% for cooling down
Weight	approx. 190g

Ordering information

INT69 VS , standard version	52 A 125
INT69 VS , with mains and fault control	52 A 125 S25
INT69 VS , with mains and fault control and reset button	52 A 125 S22
INT69 V , standard version	52 A 127
INT69 V , with mains and fault control	52 A 127 S21
INT69 V , with reset button	52 A 127 S24
INT69 V , with mains and fault control and reset button	52 A 127 S22
INT69 TM with terminal cover	52 A 240 S10

Subject to technical modification