

**DESCRIPTION**

Solenoid valve 2 way normally closed with assisted-lift diaphragm

**CONSTRUCTION**

Body and cover	Brass
Armature tube	AISI 303
Plunger and core	AISI 430FR
Springs	AISI 302
Seal material	FPM



**FEATURES**

- Maximum allowable pressure PS 25bar<sup>③</sup>
- Maximum fluid viscosity 25cSt (mm<sup>2</sup>/s)
- Ambient temperature: from -10°C to +80°C according to the coil
- Preferred mounting position with vertical coil above
- For complete diaphragm opening, a differential pressure of at least 0,15 bar is necessary

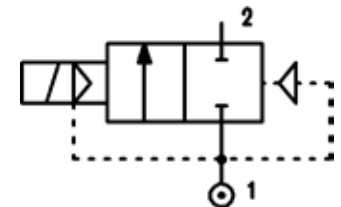

4

**OPTIONS:** Electroless nickel plating  
 us certified coils

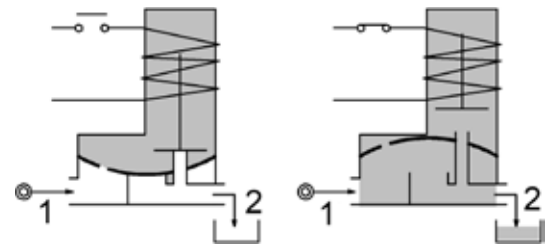

CODE ②	Connection G ISO 228	Orifice mm	Kv m <sup>3</sup> /h	Differential pressure bar			Nominal power			Coil		Seal	Temp. range °C
				Min	Max		AC Inrush	VA Holding	DC Watt	Series	Width		
					AC	DC							
E108CV12///...	3/8"	12	2	0	10	-	20	15	-	2	30	FPM=V	-10 +140
E108DV12///...	1/2"	12	2.2	0	10	-							
E108CV12///...	3/8"	12	2	0	12	10	40	30	27	5	36		
E108DV12///...	1/2"	12	2.2	0	12	10							
E108EV18///...	3/4"	18	4.5	0	9	-	40	30	-				
E108FV25///...	1"	25	8.5	0	7	-							
D108EV18///...	3/4"	18	4.5	0	-	9	-	-	27				
D108FV25///...	1"	25	8.5	0	-	8							

② Coil Example: E108FV25///52B FPM seal  
Coil 24V 50/60Hz

③ The maximum allowable pressure PS for steam 2,5bar (gauge pressure)

COILS ②	Alternating Current 50/60Hz (V)							Direct Current (V)			Electrical connection	Connectors
	12	24	48	110	220 230	240	380	12	24	48		
Series 2 Width 30	20A	20B	20C	20D	20E	20F	20G	200	201	202	DIN 43650A	PG9 code 10349000
Series 5 Width 36	52A	52B	52C	52D	52E	52F	52G	520	521	522	DIN 43650A	PG11 code 10349001

**DESCRIPTION**  
 Insulation class  
 Series 2 =F Series 5=H  
 Voltage tolerance  
 AC +15% -10%  
 DC ± 10%  
 Protection class  
 IP65 with connector fitted  
 IP00 without connector

**OPTIONS**  
 Class H insulation (series 2)  
 Cable attached  
 Special coil voltage  
 Special coil powers  
 c US certified coils

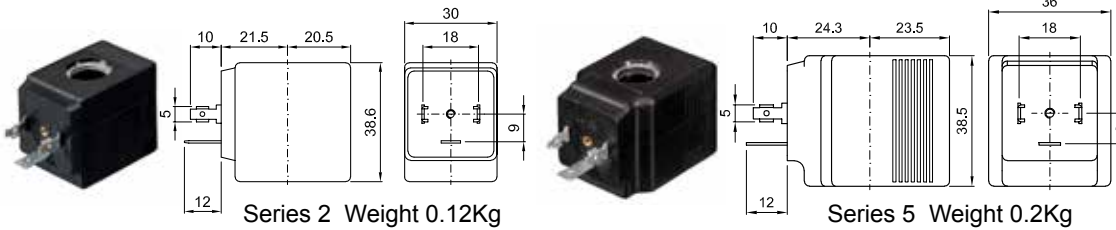

(for coil details see section 8)

### SPARE PARTS LIST

1. Coil fixing nut
2. Coil
3. Plunger
4. Armature tube with core

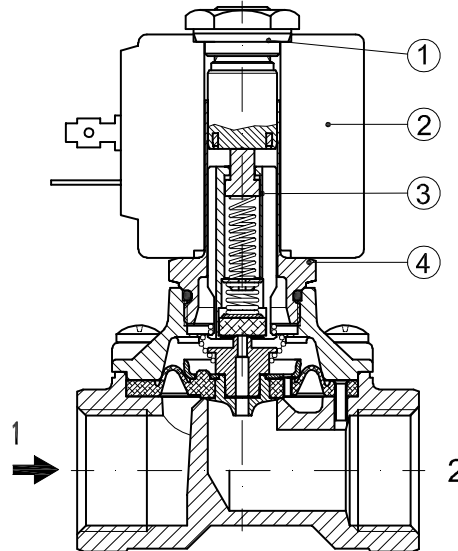

### OVERALL DIMENSION

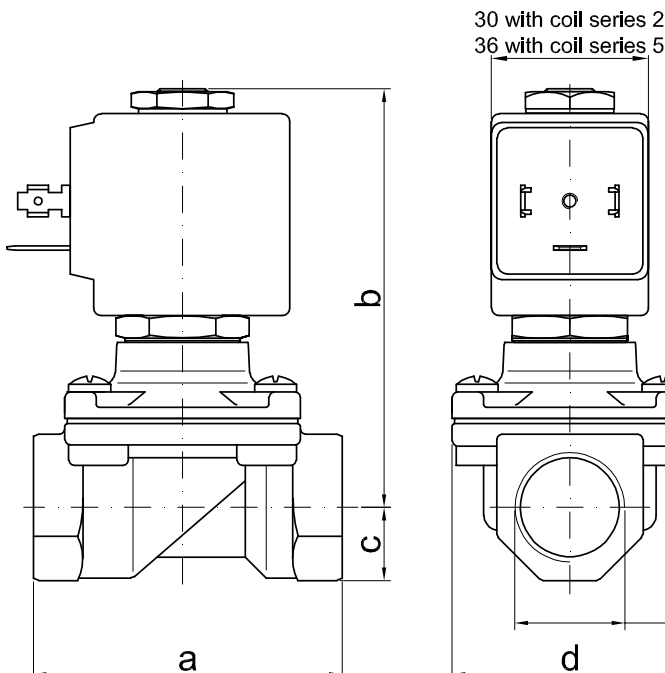

CONNECTION	a	b	c	d	weight Kg	
					series 2	series 5
G3/8"	59	83	14	45	0.52	0.60
G1/2"	59	83	14	45	0.49	0.57
G3/4"	79	90	18	55	-	0.81
G1"	96	101	20	72	-	1.22